



HELIOS · PREISSER

**MULTI-TALENTS  
IN ACTION**



**Original  
Swiss  
Pocketknife**



Partner for specialist retailers

## **Promotion Brochure Spring 2017**

In Germany at home – in demand worldwide

valid until 30.06.2017

# MULTI-TALENT CALIPERS

## DIGI-MET® Universal calipers



Measuring range can change depending on measuring inserts.

### Specification

- Stainless steel
- Factory standard
- LCD display 10 or 12.5 mm
- Locking screw
- For internal and external measurements
- Individually adaptable on problematic measuring tasks through measuring inserts with thread M 2.5
- IP65
- Shipment in wooden case

### Electronic functions

- ON/OFF switch
- **QuickStart** Electronic
- **QuickLock** Function
- Zero setting at any position
- mm/inch conversion
- Variable data output RS 232 + Digimatic + USB
- **PRESET** Function (setting a numerical value)

### Included:

- plate shaped Ø 10.0 mm
- cylindrical Ø 1.5 mm
- conical Ø 3.5 mm / 0.5 mm
- spherical Ø 7.0 mm
- spherical Ø 10.0 mm
- ball inserts Ø 4.5 mm

**PROMOTION**  
6 Measuring inserts  
included

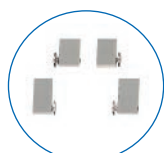

0710163

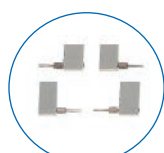

0710165

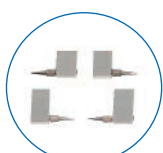

0710166

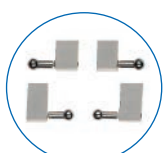

0710181

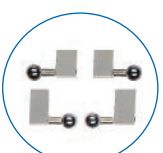

0710187

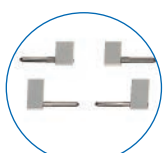

0710167

Measuring range		Jaw length		Reading		Ref. No	Promotion Price
mm	inch	mm	inch	mm	inch		Euro
300	12	90	3.5	0.01	.0005	601216002	561.00
500	20	100	4.0	0.01	.0005	601216003	719.00





## Universal caliper „Pocket - Talent“



The all-round talent that can be used for internal and external measurements. It can be combined with all common types of measuring inserts for indicators with a standard M 2.5 thread. Therefore, the small universal caliper from HELIOS · PREISSER offers you virtually unlimited measurement applications.



**PROMOTION!**  
**€ 299.-**  
INCLUDING  
SWISS POCKETKNIFE

Scan to watch



### Specification

- Stainless steel
- Factory standard
- Locking screw
- LCD display: 7.5 mm
- For internal and external measurements
- IP67
- Individually adaptable on problematic tasks through measuring inserts with thread M 2.5
- Shipment in wooden case, incl. setting standard and 2 pairs of measuring inserts
- More inserts see catalogue page 132

### Electronic functions

- ON/OFF switch
- QuickStart Electronic
- QuickLock Function
- Zero setting at any position
- mm/inch conversion
- Additional Extras Variable data output RS 232 + Digimatic + USB
- PRESET Function (setting a numerical value)

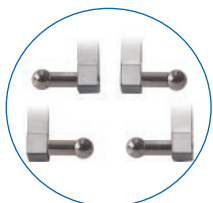

0710177\*

\*Standard shipment

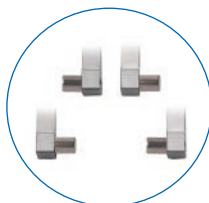

0710161\*

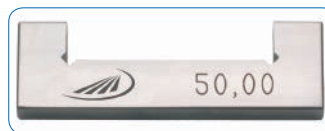

accurate setting standard



**6 cm length**  
**Multifunctional**  
**Included inside caliper case**



**Original**  
**Swiss Pocketknife**

Measuring range		Jaw length		Reading		Ref. No	Catalogue Price	Promotion Price
mm	inch	mm	inch	mm	inch			
150	6	40	1.57	0.01	.0005	601217001	339.00	299.00



# CALIPERS

## Pocket vernier caliper DUO - FIX DIN 862

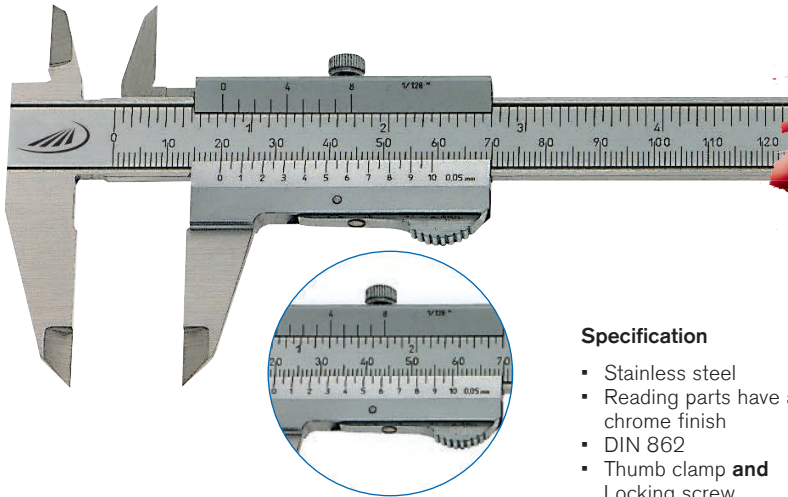

**PROMOTION PRICE**  
**€ 19.50**

Locking screw  
+ Thumb clamp  
= DUO - FIX

### Specification

- Stainless steel
- Reading parts have a satin chrome finish
- DIN 862
- Thumb clamp **and** Locking screw
- Inside cross points
- Low-set master scale
- Four way measurement
- Includes thread table
- Shipment in imitation leather case

Measuring range		Jaw length		Reading		Depth gauge	Ref. No	Catalogue Price	Promotion Price
mm	inch	mm	inch	mm	inch			Euro	Euro
150	6	40	1.57	0.05	1/128	rectangular	0190 501	24.30	19.50

## DIGI-MET® Pocket calipers DIN 862



**PROMOTION PRICE**  
**€ 82.50**

### Specification

- Inductive measuring system, resistant to damp and sweat
- Stainless steel
- LCD display: 11 mm
- DIN 862
- Locking screw
- Inside cross points
- Four way measurement
- Shipment in plastic case

### Electronic functions

- ON/OFF switch
- **QuickStart** Electronic
- **QuickLock** Function
- Zero setting at any position
- mm/inch conversion
- **PRESET** Function (setting a numerical value)

Product video  
electronic system



Measuring range		Jaw length		Reading		Depth gauge	Ref. No	Catalogue Price	Promotion Price
mm	inch	mm	inch	mm	inch			Euro	Euro
150	6	40	1.57	0.01	.0005	Ø 1.5 mm	1320 416	105.00	82.50
150	6	40	1.57	0.01	.0005	rectangular	1320 417	105.00	82.50



# DIGI-MET® Pocket caliper



**Large display**

**INCLUDES INITIAL CALIBRATION**  
Supplied with a calibration certificate

**PROMOTION!**  
**€ 119.- INCLUDING**  
**DEPTH ATTACHMENT BASE**  
**OR SWISS POCKETKNIFE**

### Specification

- LCD display: 11 mm
- DIN 862
- IP67
- Shipment in plastic case

### Electronic functions

- ON/OFF switch
- **QuickStart** Electronic
- **QuickLock** Function
- Zero setting at any position
- mm/inch conversion
- **PRESET** Function (setting a numerical value)

## Depth attachment base

**Length: 75 mm**  
**Stainless steel**

**or**

## Original Swiss Pocketknife

**6 cm length**  
**Multifunctional**  
**Included inside caliper case**

Productvideo electronic system



Measuring range		Jaw length		Reading		Depth gauge	Ref. No	Set	Catalogue Price	Promotion Price
mm	inch	mm	inch	mm	inch				Euro	Euro
150	6	40	1.57	0.01	.0005	Ø 1.5 mm	601217002	with pocketknife	152.00	119.00
150	6	40	1.57	0.01	.0005	rectangular	601217003	with pocketknife	152.00	119.00
150	6	40	1.57	0.01	.0005	Ø 1.5 mm	601216012	with depth attachment base	152.00	119.00
150	6	40	1.57	0.01	.0005	rectangular	601216013	with depth attachment base	152.00	119.00

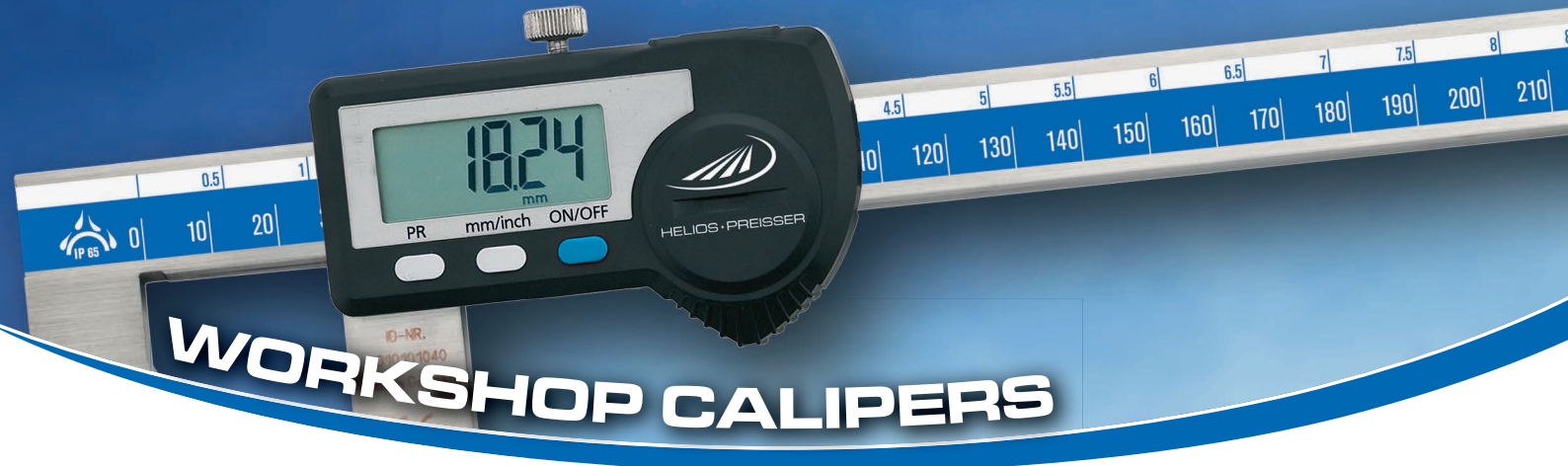

# WORKSHOP CALIPERS

## DIGI-MET® Workshop calipers IP65



### Specification

- Stainless steel
- Inductive measuring system, protection class IP65
- DIN 862
- LCD display  
10 mm for 300 mm,  
12.5 mm from 500 mm
- Locking screw
- Shipment in wooden case

### Electronic functions

- ON/OFF switch
- **QuickStart** Electronic
- **QuickLock** Function
- Zero setting at any position
- mm/inch conversion
- Variable data output  
RS 232 + Digimatic + USB
- **PRESET** Function  
(setting a numerical value)

**PROMOTION PRICES  
from € 299.-**



**With Knife points**

**Without Knife points**

Measuring range		Jaw length		Reading		Stepped jaws	Ref. No	Catalogue Price	Promotion Price	Ref. No	Catalogue Price	Promotion Price
mm	inch	mm	inch	mm	inch							
300	12	90	3.5	0,01	.0005	10	1340 522	398.00	325.00	1342 522	366.00	299.00
500	20	125	5.0	0,01	.0005	20	1340 528	759.00	625.00	1342 528	676.00	555.00
800	31	150	6.0	0,01	.0005	20	1340 532	1,025.00	845.00	1342 532	935.00	770.00
1000	39	150	6.0	0,01	.0005	20	1340 534	1,261.00	1,040.00	1342 534	1,163.00	960.00



## DIGI-MET® Pocket calipers



### Specification

- Stainless steel
- DIN 862
- IP67
- Inside cross points
- Shipment in plastic case

### Electronic functions

- ON/OFF switch
- **QuickStart** Electronic
- **QuickLock** Function
- Zero setting at any position
- mm/inch conversion
- Variable data output

## Depth attachment base

**Length: 75 mm**  
**Stainless steel**

or

## Original Swiss Pocketknife

**6 cm length**  
**Multifunctional**  
**Included inside caliper case**

Measuring range		Jaw length		Reading		Depth gauge	Ref. No	Set	Catalogue Price	Promotion Price
mm	inch	mm	inch	mm	inch				Euro	Euro
150	6	40	1.57	0.01	.0005	Ø 1.5 mm	601217004	with pocketknife	152.00	119.00
150	6	40	1.57	0.01	.0005	rectangular	601217005	with pocketknife	152.00	119.00
150	6	40	1.57	0.01	.0005	Ø 1.5 mm	601217006	with depth attachment base	152.00	119.00
150	6	40	1.57	0.01	.0005	rectangular	601217007	with depth attachment base	152.00	119.00



# EXTERNAL MICROMETERS

## External micrometers with interchangeable inserts

Up to 700 mm measuring range for **PROMOTION PRICE**

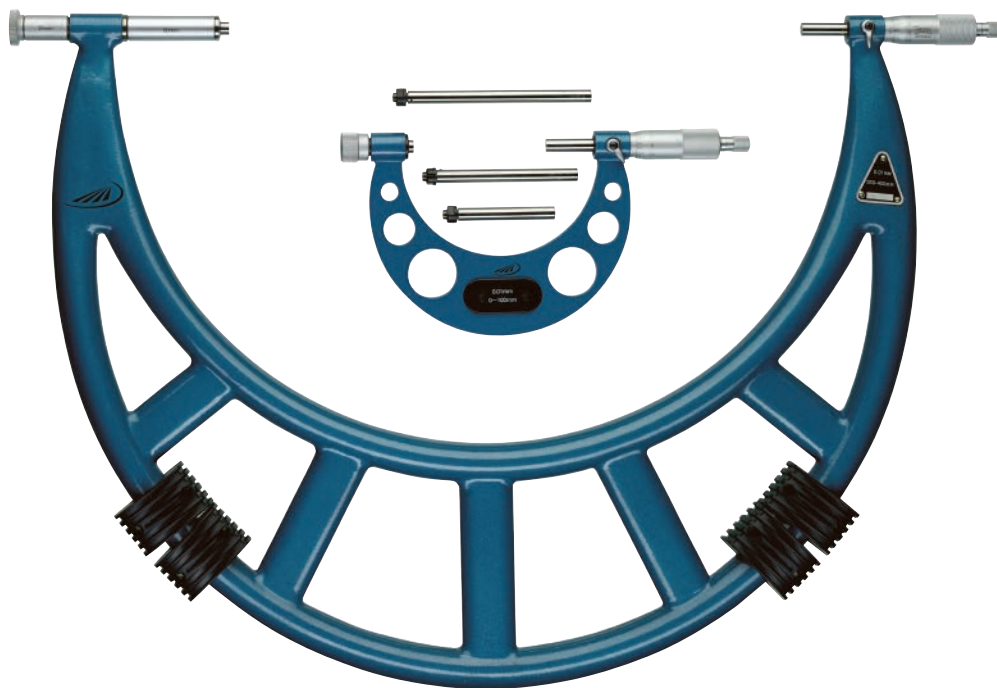

### Specification

- Reading: 0.01 mm
- Reading parts are satin chrome finished
- Locking lever
- Ratchet stop
- Carbide measuring faces
- Thermally insulated
- Coated malleable cast iron frame\* or coated light alloy frame with interchangeable anvil parts
- Includes a setting gauge
- Shipment in wooden case

Measuring range mm	Spindle dia. mm	Thimble dia. mm	Pitch mm	Ref. No	Catalogue Price Euro	Promotion Price Euro
0 - 150	8	20	0.5	0819 502*	190.00	155.00
100 - 200	8	20	0.5	0819 503*	210.00	173.00
150 - 350	8	20	0.5	0819 505*	240.00	198.00
200 - 300	8	20	0.5	0819 510*	230.00	189.00
300 - 400	8	24	0.5	0819 511	290.00	239.00
400 - 500	8	24	0.5	0819 512	330.00	272.00
500 - 600	8	24	0.5	0819 513	380.00	313.00
600 - 700	8	24	0.5	0819 514	470.00	389.00





## Digital micrometers



**PROMOTION PRICE**  
from **149,- €**

### Specification

- DIN 863-1
- Reading: 0.001 mm / .00005 inch
- LCD-display 7.5 mm
- Locking lever
- Rapid drive
- Carbide measuring faces
- Thermally insulated
- Shipment in plastic case

### Electronic functions

- ON/OFF switch
- QuickStart Electronic
- QuickLock Function
- Zero setting at any position
- mm/inch conversion
- Variable data output RS 232 + Digimatic + USB
- PRESET Function (setting a numerical value)
- From measuring range 25 - 50 mm upwards includes a setting gauge

Measuring range		Spindle dia. mm	Pitch mm	Ref. No	Catalogue Price Euro	Promotion Price Euro
mm	inch					
0 - 25	0 - 1	6.5	0.635	1865 510	181.00	149.00
25 - 50	1 - 2	6.5	0.635	1865 513	234.00	193.00
50 - 75	2 - 3	6.5	0.635	1865 517	321.00	265.00
75 - 100	3 - 4	6.5	0.635	1865 520	370.00	305.00

## Precision dial micrometers



### Specification

- DIN 863-3
- Reading: 0.01 mm
- Reading on the dial: 1 µm
- Reading parts are satin chrome finished
- Retraction stroke 1.2 mm
- Locking lever
- Carbide measuring faces
- Constant measuring force
- Thermally insulated
- Spindle made of hardened stainless steel
- Adjustable tolerance markers
- Incl. dial comparator gauge, reading 0.001 mm
- Shipment in wooden case



Measuring range mm	Spindle dia. mm	Thimble dia. mm	Pitch mm	Ref. No	Catalogue Price Euro	Promotion Price Euro
0 - 25	7.5	17.5	0.5	0850 511	538.00	495.00
25 - 50	7.5	17.5	0.5	0850 512	597.00	549.00
50 - 100	7.5	17.5	0.5	0850 514	634.00	583.00
100 - 150	7.5	17.5	0.5	0850 516	678.00	623.00
150 - 200	7.5	17.5	0.5	0850 518	709.00	652.00



**UHRTAST**

## Universal comparator gauge UHRTAST

### Specification

- Comparator gauge for external and internal measurements. Ideal for testing workpieces and setting machines.
- Versatile for comparative measurements due to the large choice of probes and measuring inserts
- Measuring range can be increased up to 2000 mm by using optional extensions
- The direction of the measuring force is reversible, thus allowing the instrument to be used for both external and internal measurements
- The setting of the universal comparator gauge can be conducted with an adjusting instrument, a master piece, a gauge block combination, a ring gauge or a micrometer
- Measuring range can be extended in conjunction with the extensions
- Shipment in wooden case (excludes a dial gauge)



Basic comparator gauge with indicator 1734

**PROMOTION PRICE**  
**€ 1,490.-**

**Watch the video**  
and get to know the  
applications of this  
product!

Scan to  
watch



### Basic comparator gauge



Internal measurement mm	External measurement mm	Ref. No	Catalogue Price Euro	Promotion Price Euro
15 - 230	5 - 220	0741 101	1,720.00	1,490.00

### Extensions



Length mm	Ref. No	Price Euro
200	0741 114	254.00
500	0741 116	388.00

### Pairs of measuring arms



Length mm	Ref. No	Price Euro
40	0741 122	249.00
80	0741 124	299.00

Further accessories in our main catalogue from page 151



### Pair of depth stop attachment for measuring arms

Ref. No	Price Euro
0741 136	232.00



### Pair of probe mounting blocks

Ref. No	Price Euro
0741 170	158.00



### Pairs of ball measuring inserts

Length mm	Ref. No	Price Euro
23	0741 178	106.00
53	0741 179	106.00

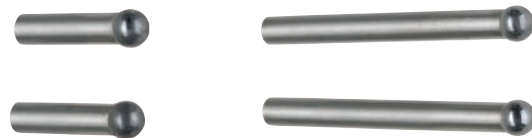

### Pair of shoulder measuring inserts

Ref. No	Price Euro
0741 172	189.00



### Pair of shoulder measuring inserts

Ref. No	Price Euro
0741 174	154.00



## DIGI-MET® Indicator



#### Specification

- Aluminium housing
- Outer ring (bezel) Ø 60 mm
- Replacement probe tip M 2.5
- IP 42
- Clamping shank Ø 8 mm
- Display unit can be rotated through 280°
- LCD display with 8.5 mm high numerals
- Factory standard
- Shipment in cardboard box

#### Electronic functions

- ON/OFF switch
- QuickStart Electronic
- QuickLock Function
- Zero setting at any position
- mm/inch conversion
- Absolute function (display can be set to zero without losing the Preset value)
- Tolerance function
- MAX-MIN function

- TIR (MAX-MIN) function
- Reversal of counting direction
- Factor input
- Individual buttons can be locked
- Variable data output RS 232 + Digimatic + USB
- PRESET Function (setting a numerical value)

The suitable indicator to the item!



Measuring range		Reading		Accuracy		Ref. No	Price Euro
mm	inch	mm	inch	mm	inch		
25.0	1.0	0.001	.00005	0.005	.0002	1734 506	421.00



**MADE IN GERMANY**

**Don't compromise, when it comes to exact measurement and examination!**

**We offer a wide range of premium-quality inspection plates and matching base stands - Made in Germany**

- Inspection plates made from special cast iron in two variations (grinded and finely grinded)
- Matching cabinets and base stands with 3-point-bearing fitting
- Rigid ripped construction
- Flatness in accordance with 876-2

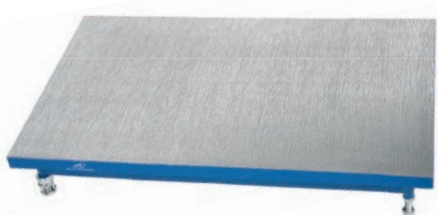

**For more information see our catalogue or visit us at [www.helios-preisser.de](http://www.helios-preisser.de)**



HELIOS · PREISSER

## DIGI-MET® Height and scribing gauges



### Specification

- Measuring beam is made from special steel
- LCD-display 11 mm
- Locking screw
- ① Fine adjustment
- ② Accurate fine adjustment on rear rack and setting wheel with pinion
- Steel base with dirt grooves
- Scribing possible from base plate level
- Factory standard

### Electronic functions

- ON/OFF switch
- Zero setting at any position
- mm/inch conversion
- Data output RS 232 Proximity
- Hold Function
- PRESET Function (setting a numerical value)
- With exchangeable scriber, carbide tipped

### Fine adjustment

### Gear rack

Measuring range mm	Measuring beam mm	Base mm	Reading mm	Ref. No	Promotion Price	Ref. No	Promotion Price
					Euro		Euro
300	30 x 12	145 x 90 x 44	0.01	601217008	519.00	601217011	639.00
600	30 x 12	189 x 118 x 44	0.01	601217009	649.00	601217012	799.00
1000	30 x 12	189 x 118 x 44	0.01	601217010	899.00	601217013	1,099.00

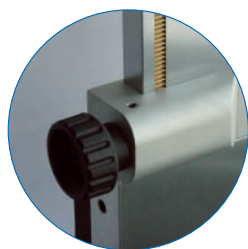

② With exchangeable scriber, carbide tipped



## Long carbide tipped scriber

Length: 150 mm  
Carbide tipped



## Height and scribing gauges

### Specification

- Measuring beam is made from special steel
- Parallax-free reading
- Locking screw
- ① Fine adjustment
- ② Accurate fine adjustment on rear rack and setting wheel with pinion
- Steel base with dirt grooves
- Scribing possible from base plate level
- Factory standard
- With exchangeable scriber, carbide tipped



### Fine adjustment

### Gear rack

Measuring range mm	Measuring beam mm	Base mm	Reading mm	Ref. No	Promotion Price	Ref. No	Promotion Price
					Euro		Euro
300	30 x 12	145 x 90 x 44	0.02	601217014	359.00	601217017	459.00
600	30 x 12	189 x 118 x 44	0.02	601217015	449.00	601217018	579.00
1000	30 x 12	189 x 118 x 44	0.02	601217016	619.00	601217019	799.00

# RULES AND SQUARES

## Graduated straight rules type A

DIN 866-A

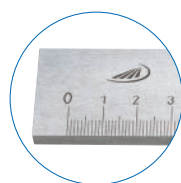

### Specification

- 10 mm protective ends
- mm graduated scale
- Shipment in cardboard box

**Straight rules and scale tapes at PROMOTION PRICES from € 19.50**

### Special steel

### Stainless steel

Length mm	Cross section mm	Ref. No	Catalogue Price Euro	Promotion Price Euro	Ref. No	Catalogue Price Euro	Promotion Price Euro
500	30 x 6	0451 101	23.90	19.50	0451 201	42.30	34.50
1000	40 x 8	0451 102	55.00	45.00	0451 202	97.00	79.00

## Graduated straight rules type B

DIN 866-B

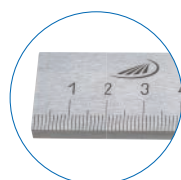

### Specification

- Scale begins directly on rules end
- 1 protective end 10 mm
- mm graduated scale
- Shipment in cardboard box

### Special steel

### Stainless steel

Length mm	Cross section mm	Ref. No	Catalogue Price Euro	Ref. No	Catalogue Price Euro
500	25 x 5	0452 101	16.00	0452 201	25.00
1000	30 x 6	0452 103	32.00	0452 203	55.00

## Steel scale tapes for circumference and diameter

### Specification

- Factory standard
- Spring band steel
- Vernier 0.1 mm
- Main scale graduation 1 mm
- Shipment in cardboard box



from 0458 104



0458 102, 0458 103

for circumference mm	for Ø mm	Ref. No	Catalogue Price Euro	Promotion Price Euro
60 - 950	20 - 300	0458 102	35.40	29.00
940 - 2200	300 - 700	0458 103	42.30	34.50
2190 - 3460	700 - 1100	0458 104	55.00	45.00
3450 - 4720	1100 - 1500	0458 105	65.00	53.00



**Made in Germany**

## Squares GG1

### Specification

- Special steel
- DIN 875
- Accuracy grade 2
- For angle testing in factory and in metal construction
- Shipment in cardboard box

**with base**

**flat**

Blade length mm		Cross section mm		Ref. No	Catalogue Price Euro	Ref. No	Catalogue Price Euro
75	x 50	15	x 5	0372 102	7.30	0373 102	5.20
100	x 70	20	x 5	0372 103	8.20	0373 103	6.00
150	x 100	25	x 5	0372 104	10.70	0373 104	8.20
200	x 130	30	x 6	0372 105	13.70	0373 105	9.90
250	x 165	35	x 7	0372 106	18.60	0373 106	13.70
300	x 175	35	x 7	0372 107	23.40	0373 107	17.50
400	x 200	35	x 7	0372 108	39.30	0373 108	26.40
500	x 250	40	x 8	0372 109	52.00	0373 109	38.60
600	x 300	40	x 8	0372 110	70.00	0373 110	52.00
750	x 375	45	x 10	0372 111	89.00	0373 111	69.00
1000	x 500	50	x 10	0372 112	122.00	0373 112	101.00



## Knife edge squares, hardened

**DIN 875**

**Highest Precision!  
Accuracy grade 00**

### Specification

- DIN 875
- Accuracy grade 00
- Stainless steel
- For exact angle and flatness testing (for example: tool making)
- Shipment in cardboard box



**PROMOTION PRICES  
from € 18.-**

Blade length mm	Cross section mm	Ref. No	Catalogue Price Euro	Promotion Price Euro
50	x 40	0388 202	22.10	18.00
75	x 50	0388 203	26.10	21.50
100	x 70	0388 204	31.40	25.00
150	x 100	0388 205	40.50	33.00
200	x 130	0388 206	60.00	49.50
300	x 200	0388 208	131.00	108.00



HELIOS • PREISSER

**Searching for something  
extraordinary?**

## **Custom-made products for customer requirements**

### **Our particular strength!**

High quality precision measuring instruments.  
Developed and manufactured by us  
according to your individual requirements  
and areas of application

**Plug gauges  
Special calipers  
Measurement devices**



000036802

- All illustrations and descriptions are valid at the time of going to press.
- All mentioned prices exclude the statutory value added tax (V.A.T.)
- No part of this promotion may be reproduced and/or duplicated, stored in a retrieval system, transmitted in any form or by means of electronic, mechanical, recording or otherwise, without the expressed prior written permission of HELIOS • PREISSER.